

UP-VW1245P1

FOR STANDBY POWER SUPPLIES.
 EXPECTED TRICKLE DESIGN LIFE: 6 - 9 YEARS AT 20°C
 ACCORDING TO EUROBAT.

DIMENSIONS (MM)



Contents indicated (including the recycle marking, etc.) are subject to change without notice. Battery case resin: flame-retardant (UL94 V-0)

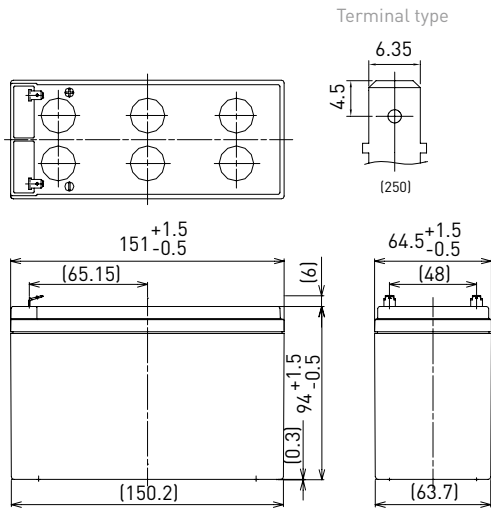

Specifications		UP-VW1245P1
Nominal voltage (V)		12
Rated power	10 minutes rate (W)	270
Nominal capacity	20 hours rate (Ah)	7.8
Dimensions	Length (mm)	64.5
	Width (mm)	151
	Total height (mm)	100
Approx. mass (kg)		2.55
Terminal type		Faston 250
Power (25°C)	30 minutes rate (W)	112
	15 minutes rate (W)	195
	10 minutes rate (W)	270
	5 minutes rate (W)	410
Impedance (mΩ)	Fully charged battery (25°C)	20
Temperature dependency of capacity (%) – 20 hours rate	40°C	102
	25°C	100
	0°C	85
	-15°C	65
Remaining capacity (25°C)	After 3 months (%)	91
	After 6 months (%)	82
	After 12 months (%)	64

DURATION OF DISCHARGE VS. DISCHARGE CURRENT

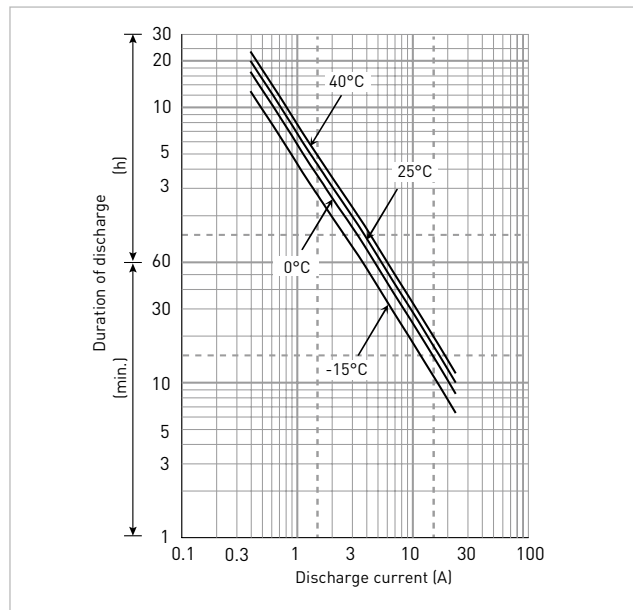

WATT TABLE (25°C)

(Wattage/battery)

Cut-off	3min.	5min.	10min.	15min.	20min.	30min.	45min.	1h	1.5h	2h	3h	4h	5h	6h	10h	20h
9.6V	530	410	270	195	159	112	82.1	65.7	45.2	34.9	26.0	20.0	16.5	13.3	8.79	4.76
9.9V	509	400	263	194	158	111	81.6	65.1	44.3	34.7	25.9	19.8	16.4	13.2	8.75	4.75
10.2V	490	390	258	193	156	110	80.8	64.4	43.4	33.9	25.6	19.7	16.2	13.1	8.65	4.73
10.5V	463	360	246	187	151	109	78.7	63.0	41.7	32.8	25.2	19.5	16.1	13.0	8.62	4.72
10.8V	434	330	234	180	146	108	78.3	61.8	41.3	31.1	24.7	19.3	15.7	12.7	8.52	4.69

AMPERE TABLE (25°C)

(Ampere/battery)

Cut-off	3min.	5min.	10min.	15min.	20min.	30min.	45min.	1h	1.5h	2h	3h	4h	5h	6h	10h	20h
9.6V	47.7	36.8	23.9	17.0	13.7	9.57	6.99	5.57	3.82	2.95	2.19	1.67	1.38	1.11	0.732	0.397
9.9V	45.8	35.9	23.5	16.9	13.6	9.55	6.95	5.50	3.75	2.93	2.17	1.66	1.37	1.10	0.729	0.396
10.2V	44.1	35.0	23.0	16.8	13.5	9.49	6.88	5.46	3.67	2.86	2.15	1.65	1.36	1.09	0.721	0.394
10.5V	41.6	32.3	22.0	16.3	13.0	9.40	6.70	5.35	3.53	2.77	2.11	1.64	1.35	1.08	0.718	0.393
10.8V	39.0	29.6	20.9	15.7	12.6	9.32	6.67	5.25	3.50	2.62	2.08	1.62	1.31	1.06	0.710	0.391

All mentioned values are average values

UP-VW1245P1

CHARGING METHOD (25°C)

Cycle use	Control voltage: 13.6V - 13.8V Initial current: 1.20A or smaller
------------------	---

CUT-OFF VOLTAGE

Discharge current	0.400A - 1.60A	1.60A - 4.00A	4.00A - 8.00A	8.00A - 16.0A	16.0A - 24.0A
Cut-off voltage	10.5V	10.2V	9.9V	9.3V	8.7V

INFLUENCE OF TEMPERATURE ON TRICKLE LIFE

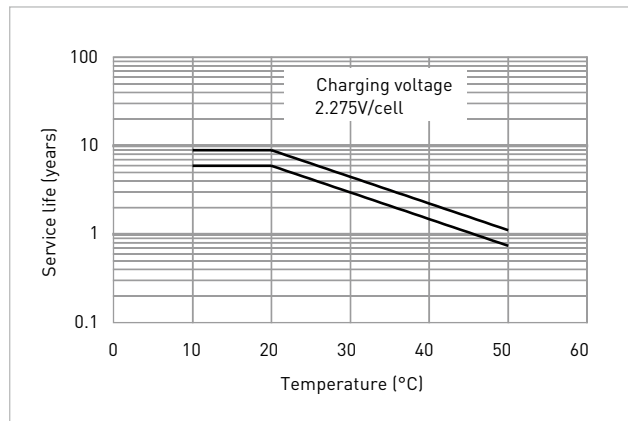

RESIDUAL CAPACITY TEST RESULT

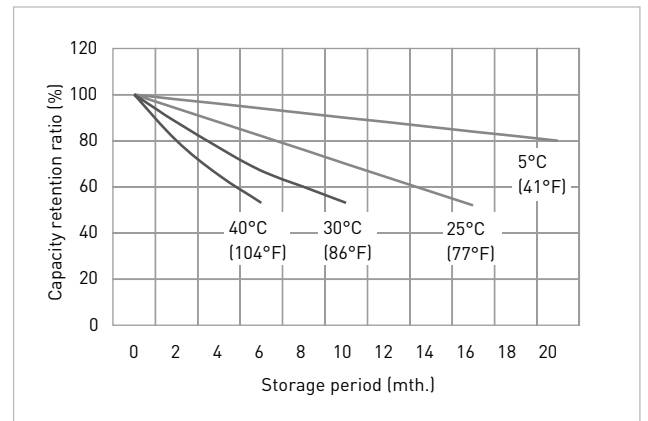

CONSTANT-VOLTAGE CONSTANT-CURRENT CHARGE CHARACTERISTICS FOR TRICKLE USE

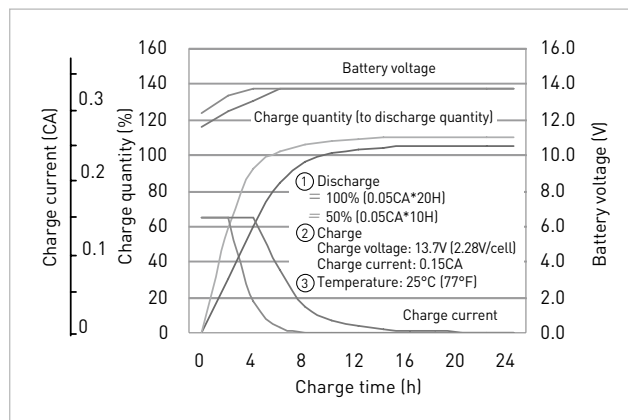

DISCHARGE CAPACITY BY TEMPERATURE AND BY DISCHARGE CURRENT

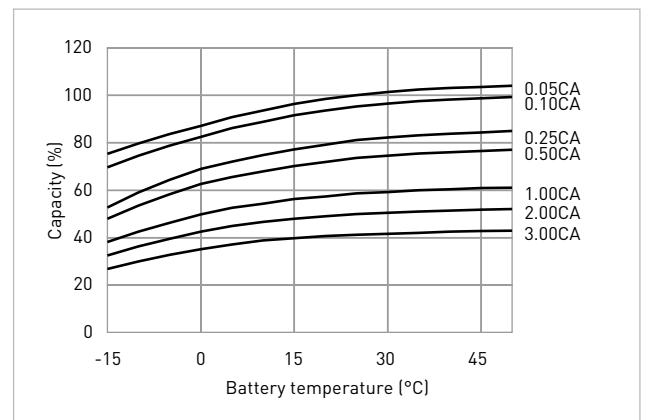

DISCHARGE CHARACTERISTICS

