

SECTION A-A

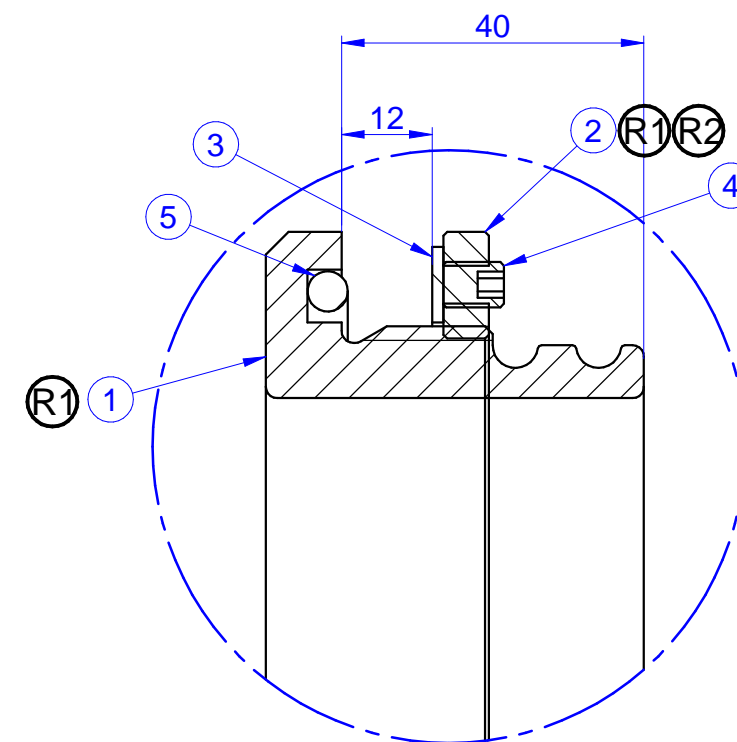

DETAIL B

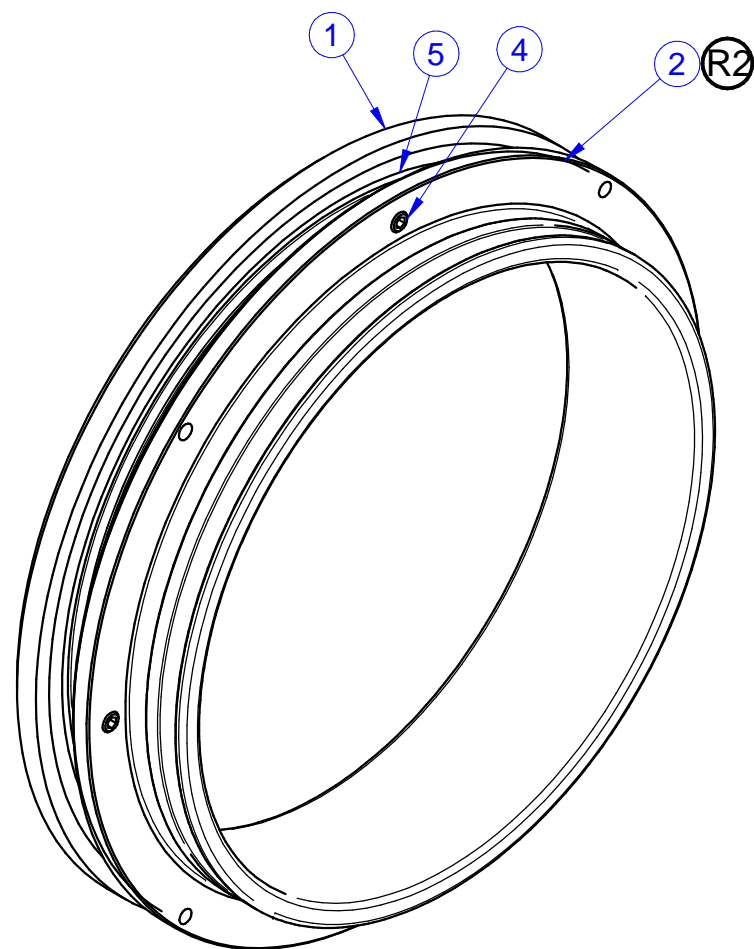

Pos.	Codice	Denominazione	Materia prima	Q.tà
5	9400010027	OR 6820 NBR NT60 DI=208.91 S=5.34		1
4	9101020036	GRANO M6X8 UNI 5923 AISI 316		4
(R1) 3	39Z1A02007.00	LAMIERA DISTANZIALE GHIERA	AISI 316L LAM 1.5 2B+LS	1
(R2)(R1) 2	39Z1A02006.00	GHIERA SERRAGGIO FLANGIA GUANTI Ø186	AL AC 100 D 250	1
(R1) 1	39Z1A02005.00	FLANGIA AVVITATA GUANTO Ø INT.186	POLIPROPILENE LASTRA SP=50MM	1